

GIRLS' HIGH SCHOOL AND COLLEGE
SESSION 2024 – 2025
CLASS – XII A,B,C & D
SUBJECT : ENGLISH LANGUAGE PROJECT

Topic : Write a descriptive essay on a Sporting Event that you have witnessed.

NOTE :

1. To be written in interleaf assignment register.
2. Write in 500 words.

GIRLS' HIGH SCHOOL AND COLLEGE
SESSION 2024 – 2025
CLASS – XII A,B,C & D
SUBJECT : ENGLISH LITERATURE PROJECT

Topic : Discuss the love – hate relationship of Charushashi and Tarapada.

Discuss the suitability of the title of the story, ' Atithi ' by Rabindranath Tagore.

NOTE :

1. To be written in interleaf assignment register.
2. Write in 1000 – 1500 words.

गर्ल्स हाई स्कूल एण्ड कॉलेज, प्रयागराज

2024 - 2025

कक्षा - XII - अ, ब, स, द

हिन्दी अधिन्यास

ग्रीष्मावकाश कार्य

निर्देश : - अभिभावकों से यह अपेक्षा की जाती है कि वे यह सुनिश्चित करें कि छात्रा हिन्दी अधिन्यास से सम्बन्धित कार्य को प्रपत्र में दिए गए निर्देशानुसार करे।

1. पृष्ठ संख्या - 01 (नीचे दायी ओर नाम, कक्षा वर्ग व अनुक्रमांक लिखे)
2. पृष्ठ संख्या - 02 (मध्य में 'हिन्दी अधिन्यास' एवं उसके नीचे सत्र - 2024-2025 लिखें)
3. पृष्ठ संख्या - 03 (मध्य में विषय - वस्तु लिखें)

विषय - वस्तु : - "इक्कीसवीं शताब्दी का जीवन आज के जीवन से भिन्न होगा।"

"क्या निराश हुआ जाए?" पाठ के आधार पर उपर्युक्त वक्तव्य को ध्यान में रखते हुए आगामी 10-15 वर्षों में पारिवारिक जीवन, शिक्षा-प्रणाली, यातायात, परिवहन, विज्ञान एवं आर्थिक क्षेत्र में होने वाले परिवर्तनों से क्या आप सहमत हैं? 1000 - 1500 शब्दों में वर्णन कीजिये कि भविष्य में आप किस प्रकार के परिवर्तनों को देखने की आप आशा रखते हैं?

4. विषय सूची

क्रम संख्या	दिनांक	विषय - वस्तु	पृष्ठ संख्या	हस्ताक्षर

5. पृष्ठ संख्या - 05 - आभार
6. पृष्ठ संख्या - 07 - (विषय-वस्तु लेखन)

नोट: - अधिन्यास से सम्बन्धित कार्य को पूर्ण करने हेतु छात्रा के लिए विज्ञान प्रयोगात्मक कॉपी (loose paper of science practical file) के पेजों का उपयोग करना अनिवार्य है।

--- END ---

GIRLS' HIGH SCHOOL & COLLEGE
SESSION : 2024 - 2025
CLASS : 12 A & B
PHYSICS ASSIGNMENT

Q1) Answer the following in brief :

- (i) Express the vector form of Coulomb's Law.
- (ii) Draw the electric field lines due to an electric dipole.
- (iii) Give expression for internal resistance of a cell.
- (iv) Give expression for capacitance of a parallel plate capacitor.
- (v) State Gauss' theorem.

Q2) Explain the following:

- (i) Explain Charge is invariant.
- (ii) Electric lines of force never intersect?
- (iii) Electric field at a point on an equipotential surface is always normal to it.
- (iv) No substance is free of Resistance.
- (v) Farad is a big unit.

Q3) Answer in detail :

- (i) Show that a spherical conductor has no field inside it. Also show that for fields at points outside it, it behaves as a point charge.
- (ii) Obtain an expression for resistance of a conductor. Find out the factors on which electrical resistance depends and how .
- (iii) Show that for an electric dipole potential at broad on position is zero whereas field is not.
- (iv) Show with the help of a neat diagram how a potentiometer can be used to determine internal resistance of a cell.
- (v) Obtain the expression for capacitance of a parallel plate capacitor with a dielectric slab of thickness 't' within it.

Q4) Solve the following :

- (i) The two plates of a parallel plate capacitor are 4 mm apart. A slab of dielectric constant 3 and thickness 3 mm is introduced between the plates with its faces parallel to them. The distance between the plates is so adjusted that the capacitance of the capacitor becomes $\frac{2}{3}$ rd of its original value. What is the new distance between the plates?
- (i) An electric dipole of moment $5 \times 10^{-9} \text{ cm}$ is aligned at 45° to a uniform electric field $E = 4 \times 10^4 \text{ N/C}$. What is the torque acting on the dipole?
- (ii) Three capacitors $C_1=3 \mu\text{F}$, $C_2=6 \mu\text{F}$ and $C_3=10 \mu\text{F}$ are connected to a 50 V battery as shown in the figure below:

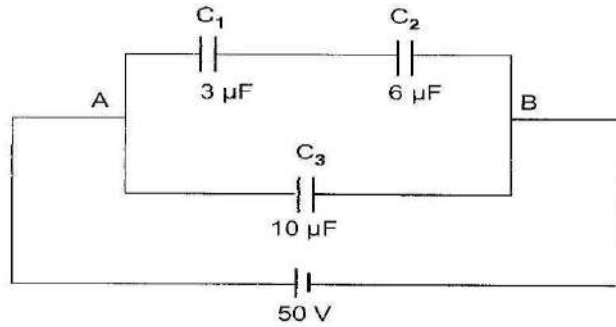

Calculate :

a) The equivalent capacitance of the circuit between points A and B.

b) The Charge on C_1 .

(iii) Three batteries of 2V, 1V and 4V with internal resistance 4Ω , 3Ω and 2Ω respectively are arranged in parallel. Find the current through each battery.

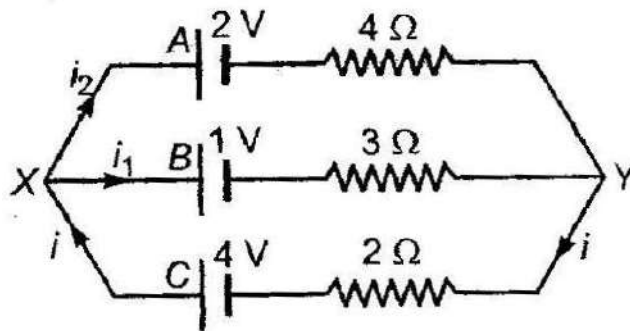

(iv) An n-type silicon sample of width $5 \times 10^{-3}m$, thickness $40 \times 10^{-5}m$ and length $3 \times 10^{-2}m$ carries a current of 2.8 mA when the voltage is applied across the length of the sample. What is the current density? If the free-electron density is $10^{22}m^{-3}$, then find how much time does it take for the electrons to travel the full length of the sample? ($e = 1.6 \times 10^{-19}C$)

- a) (v) In the figure an electric circuit is shown. When the key S is open, ammeter reads 0.7A. Find the value of V . Now S is closed and the ammeter A reading changes to 0.50A

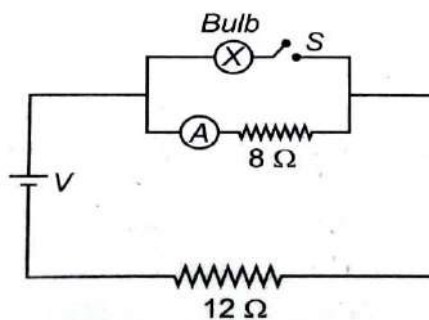

a) What is the p.d. across bulb B?

b) What is the p.d across 12Ω resistance?

*** END ***

GIRLS' HIGH SCHOOL AND COLLEGE

SESSION 2024 - 2025

CLASS XII – A & B

SUBJECT: CHEMISTRY PROJECT

Write project on the topic selected from the following topics:

1. Amino acids: Peptides, structure and classification, proteins structure and their role in the growth of living beings.
2. Nucleic Acid: DNA and RNA – their structure. Unique nature. Importance in evolution and their characteristic features.
3. Carbohydrates and their metabolism, Blood - haemoglobin and respiration.
4. Vitamins and hormones
5. Simple idea of chemical evolution.
6. Natural polymers (any five) - structure, characteristics, uses. Synthetic polymers (any five) - method of preparation, structure, characteristics and uses.
7. Types of Dyes - methods of preparation, characteristics and uses.
8. Chemicals in medicines: antiseptics, antibiotics, antacids, etc. and their uses.
9. Chemicals and chemical processes in forensic studies.
10. Insecticides, pesticides and chemical fertilisers.
11. Ancient Indian medicines and medicinal plants.
12. Organic Chemistry in Nutrition, Food Science and Biotechnology.
13. Effect of Green House Gases.
14. How Plastics have changed the world, both socially and economically.

Project to be written in the given format below:

1. Introduction / purpose
2. Contents
3. Analysis/ material aid (graph, data, structure, pie charts, histograms, diagrams, etc.)
4. Presentation
5. Conclusion
6. Bibliography

Note:

1. To be written on interleaf pages.
2. Project should be of 30-35 pages.

GIRLS' HIGH SCHOOL AND COLLEGE

SESSION: 2024 – 2025

CLASS : XII B & C

MATHS PROJECT

INSTRUCTIONS : To be written in the project file with diagrams (wherever required) to be drawn on the left side and writing matter on the right side of interleaf pages.

SECTION A IS COMPULSORY AND YOU CAN CHOOSE **EITHER** SECTION B OR SECTION C

The order to be followed

ACKNOWLEDGEMENT

INDEX (only serial no., content and page no.)

SECTION A

INTRODUCTION(of the topic not more than 6 pages)

QUESTION

SECTION B /SECTION C

INTRODUCTION (of the topic not more than 6 pages)

QUESTION

BIBLIOGRAPHY

Questions to be written with black pen and explanations or solutions with blue pen only.

Keep both the projects in one file. Cover the file with brown paper. Write Maths Project 2024-2025 in the middle and Name, Class & Section, Roll no., Session should be written at the bottom right corner.

Then cover it with cellophane sheet and at the top right corner, paste a white slip (2cm by 6cm, bordered in black) using fevicol and leave it blank.

SECTION A

Attempt any one.

Q1. Using a graph demonstrate a function which is invertible.

Q2. Verify the consistency of the system of three linear equations of two variables and verify the same graphically. Give its geometrical significance.

Q3. Explain the concept of increasing and decreasing function using geometrical significance of dy/dx . Illustrate with proper example.

Q4. Explain and illustrate (using suitable example) the concept of local maxima and minima using graph.

SECTION B

Attempt any one.

Q1. Describe the geometrical interpretation of scalar triple product for a given data, find the scalar triple product.

Q2. Using vector algebra prove the formula of compound angles ex: $\sin (A + B)$.

Q3. Find the area bounded by a circle and a parabola.

OR

SECTION C

Attempt any one.

Q1. From a given data find the regression equations by the method of least squares. Also find the angles between regression lines.

Q2. Using a suitable data, find minimum cost and maximum nutritional value by applying the concept of Diet problem.

Q3. Using suitable data, find the optimum cost in a manufacturing problem by formulation of a linear programming problem.

.....

GIRLS' HIGH SCHOOL AND COLLEGE

SESSION : 2024 – 2025

CLASS : XII – A

SUBJECT : BIOLOGY

PROJECT ASSIGNMENT

Instructions :

- The project should include the following headings :
 1. Topic
 2. Index
 3. Acknowledgement
 4. Introduction
 5. Content (subtopics)
 6. Conclusion
 7. Bibliography
- Topics are as follows :
 1. Immune System
 2. Mendelian Inheritance
 3. Human Genome Project
 4. Cancer
 5. Genetic Disorders
 6. Environmental Resistance
 7. Gene Therapy
 8. Bio Piracy
 9. DNA Fingerprinting
 10. Role of Microorganisms in industry
- The students will write a project on the topics (1-10) mentioned according to their class roll numbers (1-10) which will be repeated for the next 10 students, i.e. Topic 1 will be for roll no. 1, 11, 21, 31, 41, 51 and 61.
- The project should be of 20-25 hand written pages.
- It should also have diagrams, pictures and graphs etc. supporting the topic allotted.

GIRLS' HIGH SCHOOL AND COLLEGE, PRAYAGRAJ
SESSION 2024-2025
CLASS 12 B
SUBJECT: COMPUTER SCIENCE
PROJECT WORK

Reference Book: COMPUTER SCIENCE with Java Class 12 By Sumita Arora (Dhanpat Rai & Company)

INSTRUCTIONS: The students are expected to write **30 programs** in java. The sequence of the programs will be as follows:

1. 6 programs on Strings (display strings vertically, sorting the words of sentence, etc.)
2. 6 programs on numbers (magic composite, goldbach, isbn number, unique number etc.).
3. 4 programs on recursion (Fibonacci series, factorial, binary search, anagrams, etc.).
4. 4 programs on data structures (stack, queue, dequeue, circular queue).
5. 4 programs on inheritance
6. 4 programs on 2-D array (spiral matrix, boundary elements, non-boundary elements, sorting rows of matrix, sorting columns of matrix)
7. 2 miscellaneous programs (date programs)

Instructions for writing the project

- The students are expected to execute the above programs on the computer system on BlueJ.
- The project is to be made on **MS Word**.
- The student should type the algorithm and variable description on MS Word.
- The sequence for each program should be **algorithm, program and variable description**.
- Format of Variable Description:

<u>Name of the variable</u>	<u>Data type</u>	<u>Purpose/Description</u>

- The font size should be **12**.
- The project is to be preceded by acknowledgement and index.
- The format of index is:

S. No.	Program	Remark

- No bibliography is required.

-----END-----

GIRLS' HIGH SCHOOL & COLLEGE
SESSION: 2024-25
CLASS: XII
SUBJECT: COMMERCE
Project

Note: Parents are expected to ensure that the student should go through all the instructions given below before making the project.

INSTRUCTIONS:

1. There will be two separate Projects as per the topics given below.
 2. Order of each project :
 - **Acknowledgement** should be short and simple. Write your name, class, section and roll no. at the end. (one page)
 - **Name of the topic** (one page)
 - **Index** (only serial no. , content and page no. , should be of one page.)
 - Subject Matter of the topic (describe the topic with Introduction , relevant headings and sub headings, supported with pictures/diagrams/ graphs/ tables, as per the requirement. It should not be more than 8 to 10 pages.)
 - **Conclusion** (one page)
 - **Bibliography** (write the name of related websites and books consulted for the making of the project. One page.)
 - Each project should not be more than 15 pages including all the points mentioned above. Don't use vulgar or objectionable pictures.
 3. Relevant pictures should be pasted neatly and must be **bordered in black** along with **labelling or heading**. Use **only black and blue pens** for writing.
 4. Sample projects are given at the end of the course book. These can be read to understand the topics but don't copy the matter from here.
 5. Keep both the projects in **one file**. Cover the file with **pink chart paper**. Write **Commerce Project 2023-2024** in the middle and Name, Class, Section, Roll no., Admission no. should be written at the bottom right corner. Then cover it with cellophane sheet and at the top right corner, paste a white slip (2cm by 6cm, bordered in black) using fevicol and leave it blank.
 6. Course book, reference books and relevant websites can be used to find the subject matter of the project.
- Course Book –**
ISC Commerce Volume – II For Class XII by Dr. C.B. Gupta.

Topics for the Project:

1. Choose two companies of the same industry. Study their organisational structure. Also give information with regard to:
 - Hierarchy
 - Centralisation and Delegation of Authority
 - Flow of information (Scalar Chain)
 - Span of Control
 - Channel of Communication
2. Collect newspaper/magazine clippings of five cases filed by consumers in the Consumer Court. Find out the rights violated, and the redressal mechanism used. What was the outcome of each case?

END

GIRLS' HIGH SCHOOL AND COLLEGE

2024-25

Class 12-C

Accounts

Project - I

Instructions:- Students have to develop a case study on their own, involving two partners, who decide to start a partnership firm. They have to write atleast 15 transactions on the basis of the points mentioned below and then they have to write the journal entries, prepare ledger accounts, then Trial balance, then Trading and P/L a/c, P/L Appropriation a/c, Partners' Capital a/c and the Balance Sheet. Lastly, the Conclusion. The order as well as presentation is similar to the first project made in class 11. The length - 15 to 20 pages.

Preparation of Journal/Sub-division of Journal, Ledger, Trial balance and Financial Statements of a Partnership form of business on the basis of a case study.

- Develop a case study showing how two or more friends decide to come together and start a business with a certain amount of capital.
- Prepare their Partnership Deed including interest on Capital, Partner's salary, commission, interest on drawings, interest on partner's loan and rent paid to a partner.
- Write in detail, their transactions during the year : purchases - cash and credit, sales - cash and credit, expenses, purchase of fixed assets and depreciation charged on them, any outstanding expenses, prepaid expenses, accrued income, drawing bills of exchange, accepting bills payable etc.

- From this case study developed (which should have at least 15 transactions), pass the journal entries, post them into the ledger, prepare a Trial Balance and the Trading and Profit and Loss Account, Profit and Loss Appropriation Account and Balance Sheet.
- The various expenses, for comparison purpose, could be depicted in the form of bar diagrams, pie charts.
- Calculate relevant accounting ratios like liquidity, solvency, activity and profitability - giving their formulae and computation (all this could be part of the viva-voce).
- The ratios could also be shown graphically and/or pictorially (bar diagrams, pie charts) and if possible, could be compared with the ratios of the industry.

GIRLS' HIGH SCHOOL & COLLEGE

SESSION: 2024- 2025

CLASS: XII

SUBJECT: ECONOMICS

Project

Note: Parents are expected to ensure that the student should go through all the instructions given below before making the project.

INSTRUCTIONS:

1. There will be two separate Projects as per the topics given below.
2. Order of each project :
 - **Acknowledgement** should be short and simple. Write your name, class, section and roll no. at the end. (one page)
 - **Name of the topic** (one page)
 - **Index** (only serial no. , content and page no. , should be of one page.)
 - Subject Matter of the topic (describe the topic with Introduction , relevant headings and sub headings, supported with pictures/diagrams/ graphs/ tables, as per the requirement. It should not be more than 8 to 10 pages.)
 - **Conclusion** (one page)
 - **Bibliography** (write the name of related websites and books consulted for the making of the project. One page.)
 - Each project should not be more than 15 pages including all the points mentioned above. Don't use vulgar or objectionable pictures.
3. Relevant pictures should be pasted neatly and must be **bordered in black** along with **labelling or heading**. Use **only black and blue pens** for writing.
4. Sample projects are given at the end of the course book. These can be read to understand the topics but don't copy the matter from here.
5. Keep both the projects in **one file**. Cover the file with **brown paper**. Write **Economics project 2024-2025** in the middle and Name, Class, Section, Roll no., Admission no. should be written at the bottom right corner. Then cover it with cellophane sheet and at the top right corner, paste a white slip (2cm by 6cm, bordered in black) using fevicol and leave it blank.

6. Course book, reference books and relevant websites can be used to find the subject matter of the project.

Course Book –

ISC Economics – II For Class XII by DK. Sethi & Mrs U. Andrews

Topics for the Project:

1. PM: GATI SHAKTI SCHEME (Infrastructural development)
 - *Master plan**
 - *Ministries under the GS**
 - *Problems and challenges.**
2. CASE STUDY

“ Social and Economic Human Progress cannot be divorced from Environmental protection “

END

Girls' High School & College, Prayagraj

Session - 2024-2025

Class – 12 D

Subject – History Dissertation

Topic - Role of Sardar Vallabhbhai Patel in the Integration of Princely States.

Acknowledgement

Contents

Abstract

Introduction

Hypothesis

Methodology

Chapter – 1 - Early life and Political Career

Chapter – 2 - Integration of Princely state of Junagarh

Chapter – 3 - Integration of Hyderabad

Chapter – 4 - Integration of Jammu & Kashmir

Conclusion

Bibliography

Webliography

Picture Gallery

Instructions : Only topics and subheadings in black ink.

Rest with blue ink. It should be of approximately 2000 words.

Sample Cover Page of the Dissertation

History Dissertation



Role of Sardar Vallabhbhai Patel in the Integration of Princely States

Name –

Class / Section –

Session –

UID No : –

GIRLS' HIGH SCHOOL & COLLEGE, PRAYAGRAJ

CLASS: XII

DISSERTATION

SUBJECT: POLITICAL SCIENCE

SESSION: 2024-2025

Title Page- Role of National Human Rights Commission in safeguarding the rights of the underprivileged

Acknowledgement

Contents

Chapter I Introduction

Hypothesis- Role of National Human Rights Commission in safeguarding the rights of the underprivileged.

Methodology- The data has been collected from books, research journals, political magazines, newspapers and official websites.

Chapter II United Nations Universal Declaration of Human Rights (1948)

Chapter III Formation of National Human Rights Commission

*Composition and Functions

*Identifying the underprivileged and understanding their condition.

Chapter IV Efforts made by the National Human Rights Commission in safeguarding the rights of the underprivileged (two case studies)

Conclusion

Bibliography/Webliography

Picture Gallery (1 page)

Instructions- Word limit-2000, Max. Pages- 20.

File to be covered with brown paper.

END

GIRLS' HIGH SCHOOL & COLLEGE

SUBJECT: SOCIOLOGY PROJECT

CLASS: XII D

SESSION: 2024-2025

Note: Parents are expected to ensure that the students should go through all the instructions given below before making the project.

INSTRUCTIONS:

- Students are expected to write the project on given topics.
- The word limit is 1500 - 2000 words for one project.
- Students are expected to adhere with following instructions-

Description of the project:

- 1) Topic in Bold
- 2) Acknowledgement
- 3) Index (write according to the serial no., page no., content)
- 4) Introduction (related with specific topic)
- 5) Body of the project (describe the topic with relevant headings and sub headings.)
- 6) Case Study (at least 2 cases)
- 7) Conclusion (summary of the project should not be more than two pages)
- 8) Bibliography (write only referred books)
- 9) Webliography (write the referred websites)
- 10) Keep both the projects in one file.

Topics:

- 1. Rules and forms of marriage**
- 2. Social Movements**

NOTE:

Relevant pictures should be pasted neatly and must be **bordered in black** along with **labeling or heading**.

Students will collect the data for project from different sources available to them and compile them in a file, neatly covered with purple cover and a cellophane cover over it. Write Sociology Project 2024-25 in the middle and write your name, class, admission no. at the bottom right corner. At the top right corner, paste a white slip (2cm by 6cm, bordered in black) leave it blank.

****END****

GIRLS' HIGH SCHOOL & COLLEGE

SESSION :2024 – 2025

CLASS : XII

SUBJECT – LEGAL STUDIES

Project

Note: Parents are expected to ensure that the student should go through all the instructions given below before making the project.

Topics for the Project-

1. "Changing the Decision -Making Process : From Lawsuit to Arbitration." Analyse with objectivity.
2. Briefly Discuss the Human Rights Act with special reference to Amendment Act 2006.

Follow the given Instructions-

1. There will be **two separate projects** as per the topics given above.
2. Order of **each** project :
 - Acknowledgement
 - Name of the topic
 - Index (write according to the serial no, page no ,content)
 - Introduction (related with specific topic)
 - Body of the Project (include case studies, pictures and explanation of the project)
 - Conclusion (summary of the project, should not be more than two pages)
 - Bibliography(write only referred books)
 - Webliography (write down the referred websites)
 - Each project should not be more than 20 pages.
 - Keep both the projects in one file. Cover the file with brown paper. Write Legal Studies Project 2024-25 in the middle and write your name , class , admission no at the bottom right corner.
 - You can refer course book or any other relevant book related with topics.

END

